



6FM18 (12V18.0Ah)

6FM18 is a general purpose battery with 5 years life in standby service, or more than 260 cycles at 100% D.O.D by cyclic use. As with all QiangJun batteries, all FM models are rechargeable, highly efficient, leak proof and maintenance free.



Specification

Cells Per Unit	6
Voltage Per Unit	12
Capacity	18.0Ah@ 20hr-rate to 1.75V per cell @ 25°C
Weight	Approx. 5.3 Kg
Max. Discharge Current	180 A (5 sec)
Internal Resistance	Approx. 14 m
Operating Temperature Range	Discharge: -20°C~60°C Charge: 0°C~50°C Storage: -20°C~60°C
Normal Operating Temperature Range	25°C±5°C
Float charging Voltage	13.6 to 13.8 VDC/unit Average at 25°C
Recommended Maximum Charging Current Limit	5.4 A
Equalization and Cycle Service	14.4 to 15.0 VDC/unit Average at 25°C
Self Discharge	QiangJun batteries can be stored for more than 6 months at 25°C. Please charge batteries before using. For higher temperature, the time interval will be shorter.
Terminal	Faston F3/F13
Container Material	A.B.S. (UL94-HB) Flammability resistance of UL94-V2 can be available upon request.



Dimensions

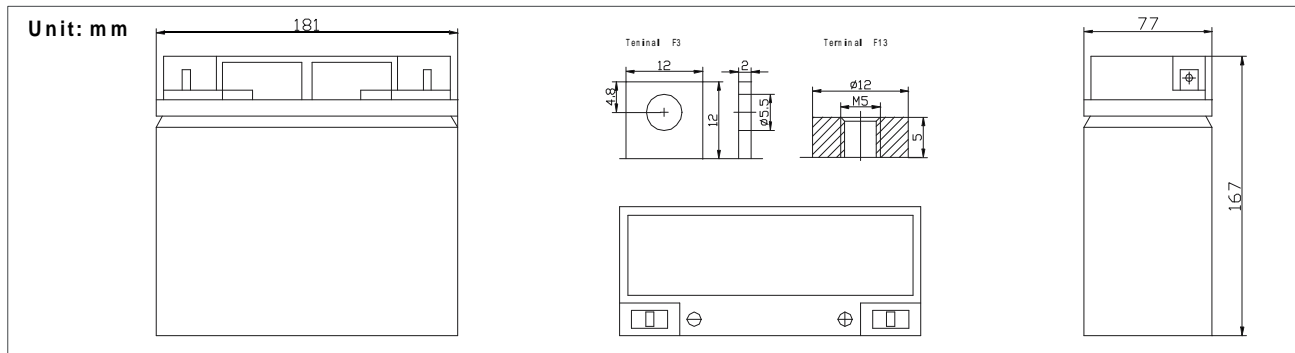

Constant Current Discharge Characteristics Unit: A(25°C)

F.V/Time	5MIN	10MIN	15MIN		1HR	2HR	3HR	4HR	5HR	8HR	10HR	20HR
1.60V	74.7	50.0	38.4	21.1	12.5	7.49	4.61	3.78	3.04	2.23	1.76	0.99
1.67V	69.9	46.6	36.1	20.8	12.4	7.43	4.59	3.76	3.02	2.23	1.75	0.95
1.70V	66.2	45.2	35.3	20.6	12.3	7.42	4.57	3.74	3.01	2.23	1.73	0.94
1.75V	59.8	42.3	33.4	20.2	12.2	7.33	4.55	3.73	2.99	2.23	1.71	0.90
1.80V	53.4	39.4	31.6	19.7	12.0	7.20	4.52	3.71	2.97	2.21	1.67	0.86
1.85V	47.0	36.5	29.7	19.2	11.8	7.09	4.48	3.69	2.95	2.21	1.66	0.85

Constant Power Discharge Characteristics Unit: W(25°C)

F.V/Time	5MIN	10MIN	15MIN	30MIN	1HR	2HR	3HR	4HR	5HR	8HR	10HR	20HR
1.60V	144	93.6	76.1	42.2	25.0	15.0	9.20	7.52	7.15	4.48	3.51	1.96
1.67V	135	90.0	72.2	41.5	24.9	14.9	9.18	7.51	7.09	4.48	3.47	1.89
1.70V	132	87.3	70.5	41.3	24.8	14.8	9.16	7.51	7.07	4.45	3.44	1.85
1.75V	120	83.7	66.8	40.3	24.4	14.6	9.11	7.45	7.06	4.43	3.40	1.78
1.80V	107	78.3	63.1	39.3	24.0	14.4	9.04	7.40	7.04	4.41	3.35	1.73
1.85V	94.1	72.9	59.5	38.4	23.6	14.2	8.96	7.34	7.02	4.41	3.29	1.67

All mentioned values are average values.

6FM 18

12V18.0Ah



Temperature effects curve

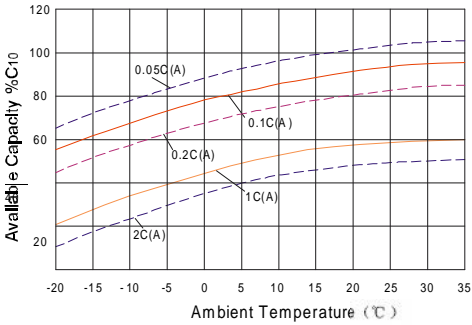

Storage characteristic

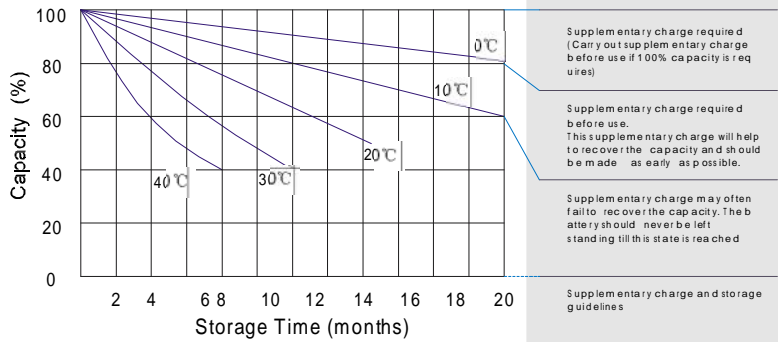

Life characteristics of cyclic use

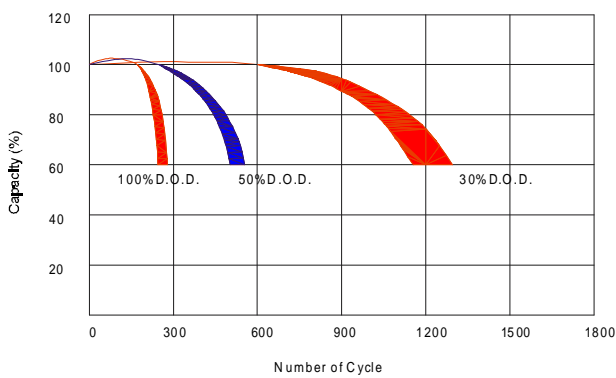

Effect of Temperature on long term float life

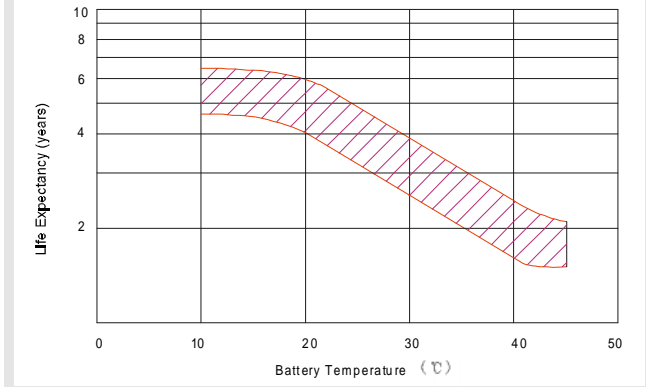

Charge characteristic curve for standby use

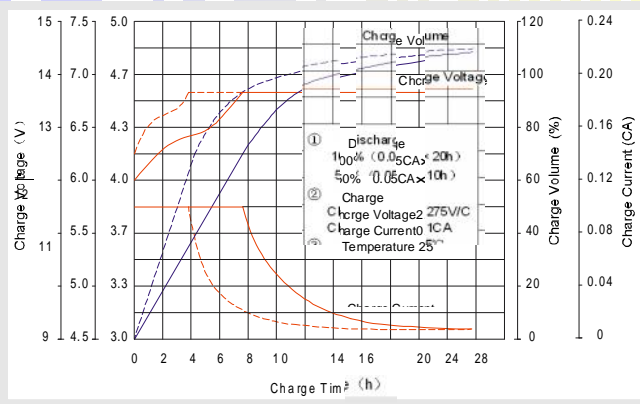

Discharge characteristic curve

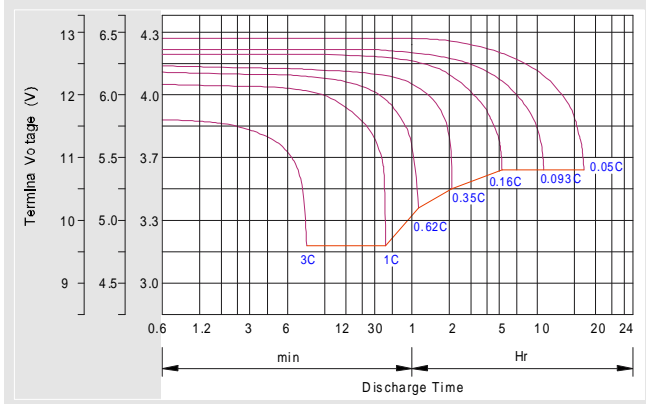

Charging Procedures

Application	Charge Voltage (V)			Max. Charge Current
	Temperature	Set point	Allowable range	
Cycle Use	25°C	14.7	14.4~15.0	0.3C
Standby	25°C	13.7	13.6~13.8	0.3C

Discharge Current VS. Discharge Voltage

Final Discharge Voltage V/cell	1.75V	1.70V	1.60V
Discharge Current (A)	(A) ≤ 0.2C	0.2C < (A) <	(A) ≥ 1.0C

Charge the batteries at least once every six months, if they are stored at 25°C.

Charging Method:

Constant Voltage	-0.2Cx2h +14.4~15.0V,24h,Max. Current 0.3CA
Constant Current	-0.2Cx2h +0.1CAx12h
Fast	-0.2Cx2h +0.3CAx4h

Charging Procedures(6V series)

Application	Charge Voltage (V)			Max. Charge Current
	Temperature	Set point	Allowable range	
Cycle Use	25°C	7.35	7.25~7.45	0.3C
Standby	25°C	6.85	6.8~6.9	0.3C

QIANGJING BATTERY CO.,LTD
 Mudan Road Xiacheng Town,
 Yuefang Distrct,
 Xiangtan City, Hunan P.R.China