



# 6FM1.6 (12V1.6Ah)



6FM1.6 is a general purpose battery with 5 years life in standby service, or more than 260 cycles at 100% D.O.D by cyclic use. As with all QiangJun batteries, all FM model are rechargeable, highly efficient, leak proof and maintenance free.

## Specification

Cells Per Unit	6
Voltage Per Unit	12
Capacity	1.6Ah @ 20hr-rate to 1.75V per cell @ 25°C
Weight	Approx. 0.6 Kg
Max. Discharge Current	20 A (5 sec)
Internal Resistance	Approx. 110 m
Operating Temperature Range	Discharge: -20°C~60°C Charge: 0°C~50°C Storage: -20°C~60°C
	25°C ±5°C
	13.6 to 13.8 VDC/unit Average at 25°C
	0.6 A
	14.4 to 15.0 VDC/unit Average at 25°C
Self Discharge	QiangJun batteries can be stored for more than 6 months at 25°C. Please charge batteries before using. For higher temperature, the time interval will be short
Terminal	Terminal T10
Container Material	A.B.S. (UL94-HB) Flammability resistance of UL94-V2 can be available upon request.



## Dimensions

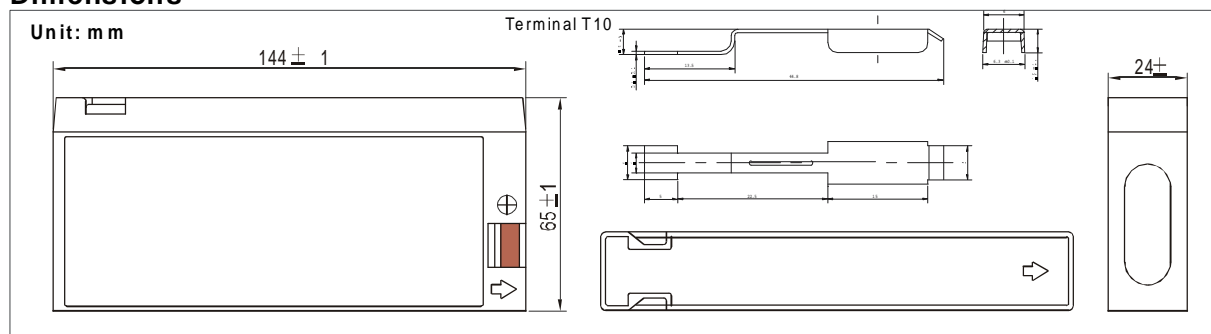

### Constant Current Discharge Characteristics Unit: A(25°C)

F.V/Time	5MIN	10MIN	15MIN	3	1HR	2HR	3HR	4HR	5HR	8HR	10HR	20HR
1.60V	6.64	4.44	3.41	1.88	1.11	0.67	0.41	0.34	0.27	0.20	0.16	0.09
1.67V	6.22	4.14	3.21	1.85	1.10	0.66	0.41	0.33	0.27	0.20	0.16	0.08
1.70V	5.88	4.01	3.13	1.83	1.10	0.66	0.41	0.33	0.27	0.20	0.15	0.08
1.75V	5.31	3.76	2.97	1.79	1.08	0.65	0.40	0.33	0.27	0.20	0.15	0.08
1.80V	4.74	3.50	2.81	1.75	1.06	0.64	0.40	0.33	0.26	0.20	0.15	0.08
1.85V	4.18	3.24	2.64	1.71	1.05	0.63	0.40	0.33	0.26	0.20	0.15	0.08

### Constant Power Discharge Characteristics Unit: W(25°C)

F.V/Time	5MIN	10MIN	15MIN	30MIN	1HR	2HR	3HR	4HR	5HR	8HR	10HR	20HR
1.60V	12.8	8.32	6.76	3.75	2.22	1.33	0.82	0.67	0.64	0.40	0.31	0.17
1.67V	12.0	8.00	6.41	3.69	2.21	1.32	0.82	0.67	0.63	0.40	0.31	0.17
1.70V	11.8	7.76	6.27	3.67	2.21	1.32	0.81	0.67	0.63	0.40	0.31	0.16
1.75V	10.6	7.44	5.94	3.58	2.17	1.30	0.81	0.66	0.63	0.39	0.30	0.16
1.80V	9.49	6.96	5.61	3.50	2.13	1.28	0.80	0.66	0.63	0.39	0.30	0.15
1.85V	8.36	6.48	5.29	3.41	2.10	1.26	0.80	0.65	0.62	0.39	0.29	0.15

All mentioned values are average values.

# 6FM1.6

12V1.6Ah



## Temperature effects curve

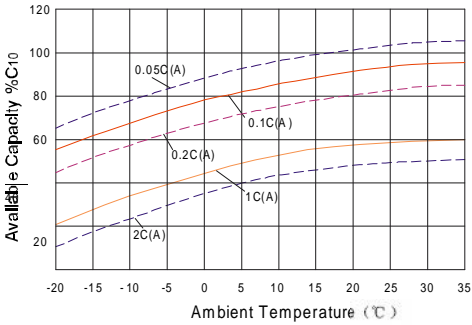

## Storage characteristic

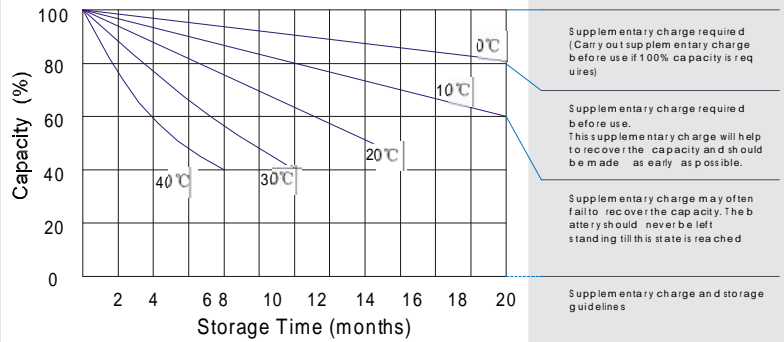

## Life characteristics of cyclic use

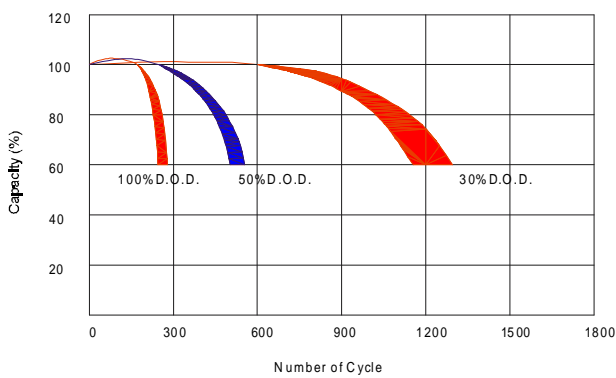

## Effect of Temperature on long term float life

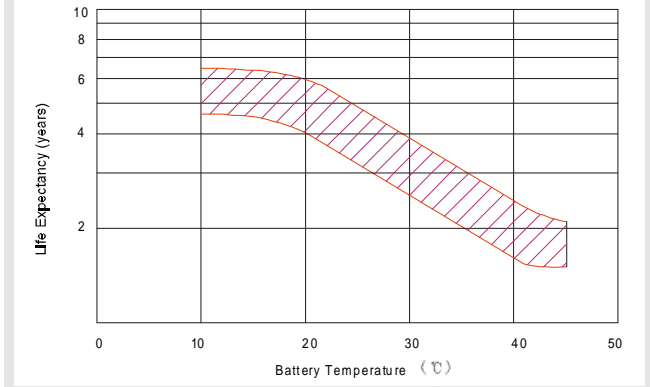

## Charge characteristic curve for standby use

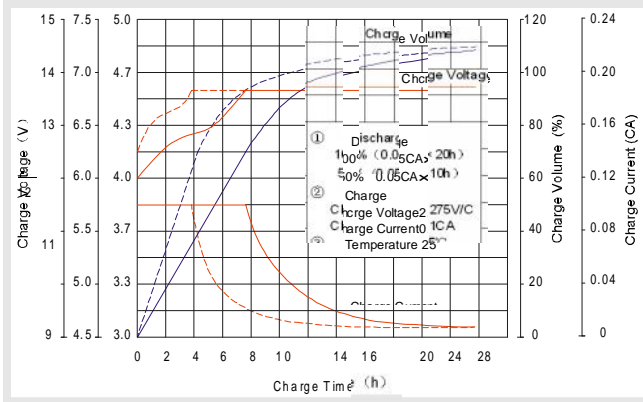

## Discharge characteristic curve

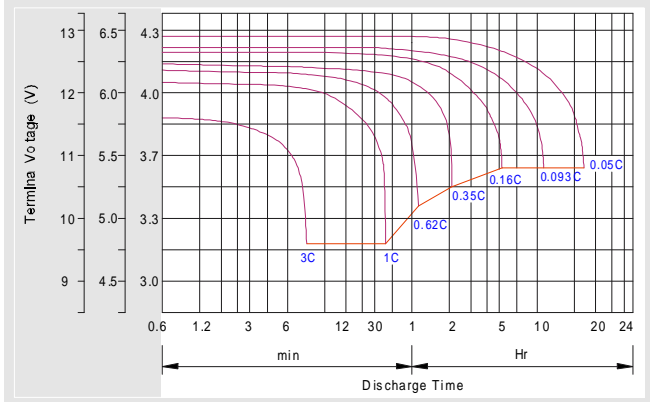

## Charging Procedures

Application	Charge Voltage (V)			Max. Charge Current
	Temperature	Set point	Allowable range	
Cycle Use	25°C	14.7	14.4~15.0	0.3C
Standby	25°C	13.7	13.6~13.8	0.3C

## Discharge Current VS. Discharge Voltage

Final Discharge Voltage V/cell	1.75V	1.70V	1.60V
Discharge Current (A)	(A) ≤ 0.2C	0.2C < (A) <	(A) ≥ 1.0C

Charge the batteries at least once every six months, if they are stored at 25°C.

## Charging Method:

Constant Voltage	14.4~15.0V, 5~11h, Max. Current 0.1CA
Constant Current	0.1CA×5h
Fast	0.3CA×1.7h

## Charging Procedures(6V series)

Application	Charge Voltage (V)			Max. Charge Current
	Temperature	Set point	Allowable range	
Cycle Use	25°C	7.35	7.25~7.45	0.3C
Standby	25°C	6.85	6.8~6.9	0.3C

**QIANGJING BATTERY CO.,LTD**  
 Mudan Road Xiacheng Town,  
 Yuefang District,  
 Xiangtan City, Hunan P.R.China