



3FM4.2B

3FM4.2B is a general purpose battery with 5 years life in standby service, or more than 260 cycles at 100% D.O.D by cyclic use. As with all QiangJun batteries, all FM models are rechargeable, highly efficient, leak proof and maintenance free.



Specification

Cells Per Unit	3
Voltage Per Unit	6
Capacity	4.2Ah @ 20hr-rate to 1.75V per cell @ 25°C
Weight	Approx. 0.72 Kg
Max. Discharge Current	40 A (5 sec)
Internal Resistance	Approx. 33 m
Operating Temperature Range	Discharge: -20°C~60°C Charge: 0°C~50°C Storage: -20°C~60°C
Normal Operating Temperature Range	25°C±5°C
Float charging Voltage	6.8 to 6.9 VDC/unit Average at 25°C
Recommended Maximum Charging Current Limit	1.2 A
Equalization and Cycle Service	7.25 to 7.45 VDC/unit Average at 25°C
Self Discharge	QiangJun batteries can be stored for more than 6 months at 25°C. Please charge batteries before using. For higher temperature, the time interval will be shorter.
Terminal	Terminal T6
Container Material	A. B. S. (UL94-HB) Flammability resistance of UL94-V2 can be available upon request.



Dimensions

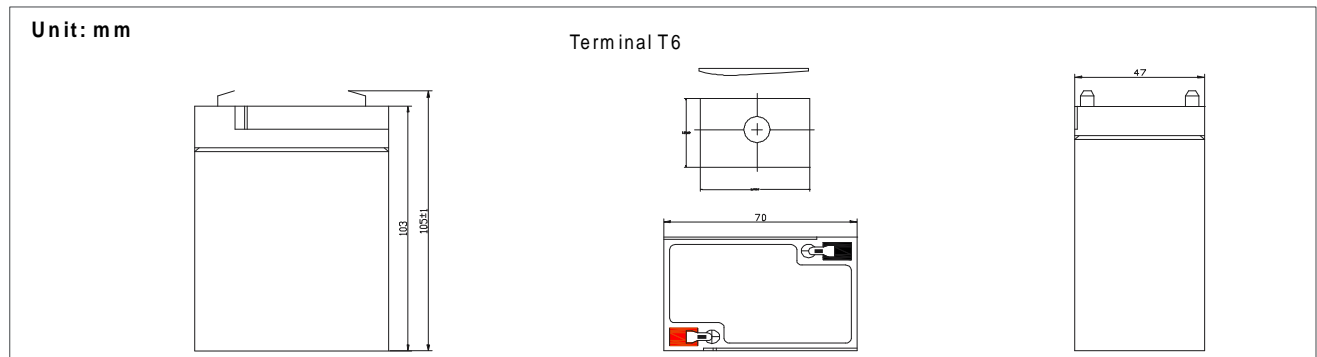

Constant Current Discharge Characteristics Unit: A (25°C)

F.V/Time	5MIN	10MIN	15MIN	30MIN	1HR	2HR	3HR	4HR	5HR	8HR	10HR	20HR
1.60V	17.4	11.7	8.96	4.93	2.91	1.75	1.08	0.88	0.71	0.52	0.41	0.23
1.67V	16.3	10.9	8.42	4.85	2.90	1.73	1.07	0.88	0.71	0.52	0.41	0.22
1.70V	15.4	10.5	8.23	4.81	2.88	1.73	1.07	0.87	0.70	0.52	0.40	0.22
1.75V	13.9	9.86	7.80	4.70	2.84	1.71	1.06	0.87	0.70	0.52	0.40	0.21
1.80V	12.5	9.19	7.37	4.59	2.79	1.68	1.05	0.87	0.69	0.52	0.39	0.20
1.85V	11.0	8.51	6.94	4.48	2.76	1.65	1.05	0.86	0.69	0.52	0.39	0.20

Constant Power Discharge Characteristics Unit: W (25°C)

F.V/Time	5MIN	10MIN	15MIN	30MIN	1HR	2HR	3HR	4HR	5HR	8HR	10HR	20HR
1.60V	33.6	21.8	17.7	9.85	5.83	3.49	2.15	1.76	1.67	1.05	0.82	0.46
1.67V	31.5	21.0	16.8	9.69	5.81	3.47	2.14	1.75	1.65	1.05	0.81	0.44
1.70V	30.9	20.4	16.5	9.63	5.80	3.46	2.14	1.75	1.65	1.04	0.80	0.43
1.75V	27.9	19.5	15.6	9.40	5.70	3.41	2.13	1.74	1.65	1.03	0.79	0.42
1.80V	24.9	18.3	14.7	9.18	5.60	3.36	2.11	1.73	1.64	1.03	0.78	0.40
1.85V	21.9	17.0	13.9	8.95	5.51	3.31	2.09	1.71	1.64	1.03	0.77	0.39

All mentioned values are average values.

3FM4.2B

6V4.2Ah



Temperature effects curve

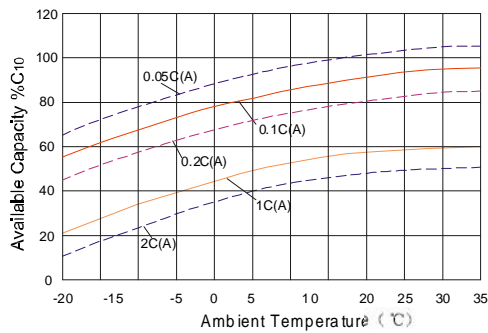

Storage characteristic

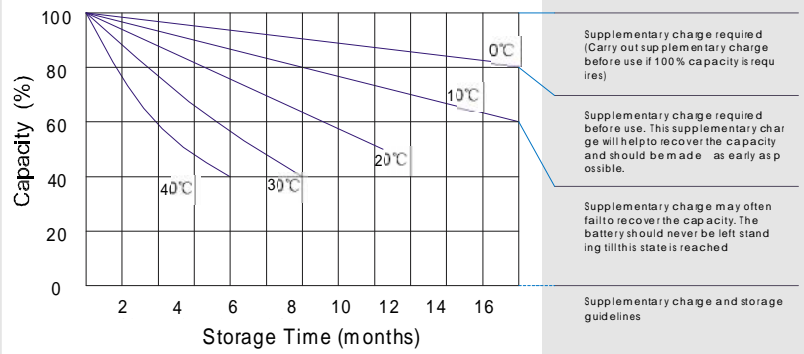

Life characteristics of cyclic use

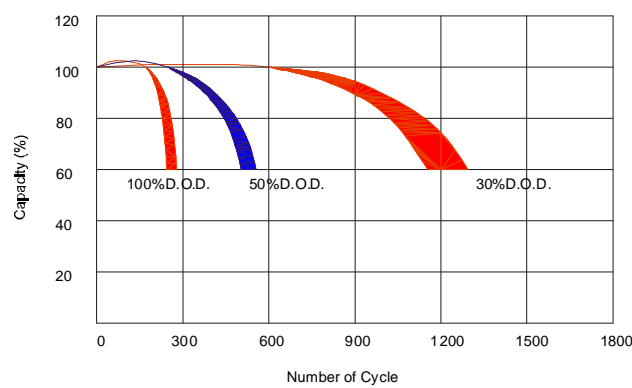

Effect of Temperature on long term float life

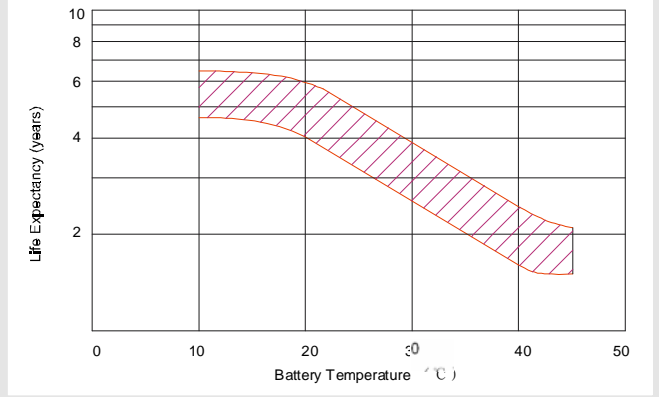

Charge characteristic curve for standby use

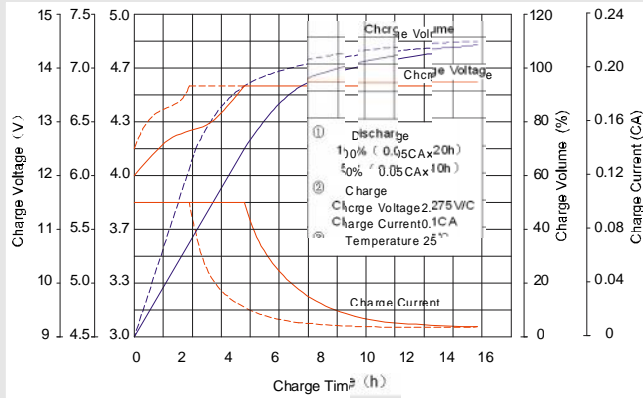

Discharge characteristic curve

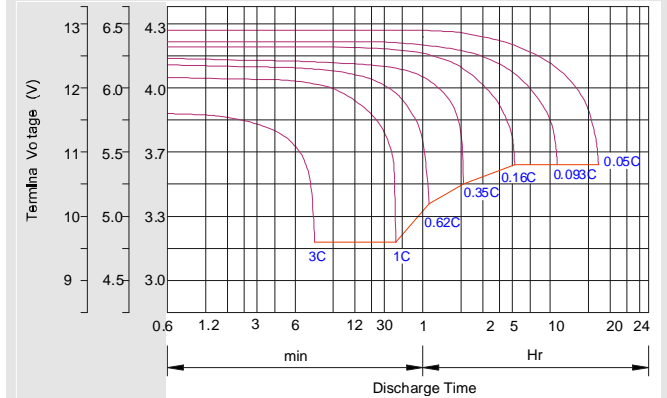

Charging Procedures

Application	Charge Voltage (V)			Max. Charge Current
	Temperature	Set point	Allowable range	
Cycle Use	25°C	14.7	14.4-15.0	0.3C
Standby	25°C	13.7	13.6-13.8	0.3C

Discharge Current VS. Discharge Voltage

Final Discharge Voltage V/cell	1.75V	1.70V	1.60V
Discharge Current (A)	$A < 0.2C$	$0.2C < (A) < 1.0C$	$(A) \geq 1.0C$

Charge the batteries at least once every six months, if they are stored at 25°C.

Charging Method:

Constant Voltage	7.25-7.45V, 5-11h, Max. Current 0.1CA
Constant Current	0.1CAx5h
Fast	0.3CAx1.7h

Charging Procedures(6V series)

Application	Charge Voltage (V)			Max. Charge Current
	Temperature	Set point	Allowable range	
Cycle Use	25°C	7.35	7.25-7.45	0.3C
Standby	25°C	6.85	6.8-6.9	0.3C

QIANGJING BATTERY CO.,LTD
 Mudan Road Xiacheng Town,
 Yuefang District,
 Xiangtan City, Hunan P.R.China