



3FM3.2 (6V3.2Ah)



3FM3.2 is a general purpose battery with 5 years life in standby service, or more than 260 cycles at 100% D.O.D by cyclic use. As with all QiangJun batteries, all FM models are rechargeable, highly efficient, leak proof and maintenance free.

Specification

Cells Per Unit	3
Voltage Per Unit	6
Capacity	3.2Ah@ 20hr-rate to 1.75V per cell @ 25°C
Weight	Approx. 0.7 Kg
Max. Discharge Current	32 A (5 sec)
Internal Resistance	Approx. 25 m
Operating Temperature Range	Discharge: -20°C~60°C Charge: 0°C~50°C Storage: -20°C~60°C
Normal Operating Temperature Range	25°C±5°C
Float charging Voltage	6.8 to 6.9 VDC/unit Average at 25°C
Recommended Maximum Charging Current Limit	0.96 A
Equalization and Cycle Service	7.25 to 7.45 VDC/unit Average at 25°C
Self Discharge	QiangJun batteries can be stored for more than 6 months at 25°C. Please charge batteries before using. For higher temperature, the time interval will be shorter.
Terminal	Faston Tab 187(F1)
Container Material	A.B.S. (UL94-HB) Flammability resistance of UL94-V2 can be available upon request.



Dimensions

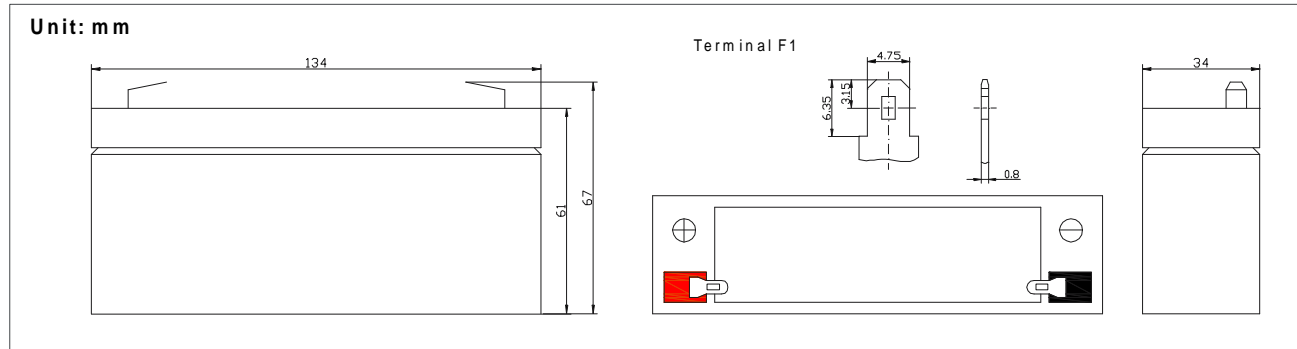

Constant Current Discharge Characteristics Unit: A(25°C)

F.V/Time	5 MIN	10 MIN	15 MIN	1 HR	2 HR	3 HR	4 HR	5 HR	8 HR	10 HR	20 HR	
1.60V	13.3	8.88	6.83	3.75	2.22	1.33	0.82	0.67	0.54	0.40	0.31	0.18
1.67V	12.4	8.28	6.42	3.70	2.21	1.32	0.82	0.67	0.54	0.40	0.31	0.17
1.70V	11.8	8.03	6.27	3.67	2.19	1.32	0.81	0.67	0.53	0.40	0.31	0.17
1.75V	10.6	7.51	5.94	3.58	2.16	1.30	0.81	0.66	0.53	0.40	0.30	0.16
1.80V	9.49	7.00	5.61	3.50	2.13	1.28	0.80	0.66	0.53	0.39	0.30	0.15
1.85V	8.36	6.49	5.29	3.41	2.10	1.26	0.80	0.66	0.52	0.39	0.29	0.15

Constant Power Discharge Characteristics Unit: W(25°C)

F.V/Time	5 MIN	10 MIN	15 MIN	30 MIN	1 HR	2 HR	3 HR	4 HR	5 HR	8 HR	10 HR	20 HR
1.60V	25.6	16.6	13.5	7.51	4.44	2.66	1.64	1.34	1.27	0.80	0.62	0.35
1.67V	24.0	16.0	12.8	7.39	4.43	2.64	1.63	1.33	1.26	0.80	0.62	0.34
1.70V	23.5	15.5	12.5	7.34	4.42	2.64	1.63	1.33	1.26	0.79	0.61	0.33
1.75V	21.3	14.9	11.9	7.16	4.34	2.60	1.62	1.32	1.25	0.79	0.60	0.32
1.80V	19.0	13.9	11.2	6.99	4.27	2.56	1.61	1.32	1.25	0.78	0.60	0.31
1.85V	16.7	13.0	10.6	6.82	4.20	2.52	1.59	1.31	1.25	0.78	0.59	0.30

All mentioned values are average values.

3FM3.2

6V3.2Ah



Temperature effects curve

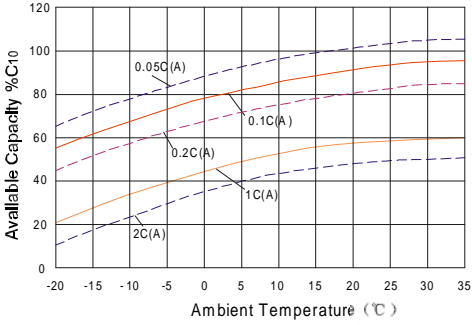

Storage characteristic

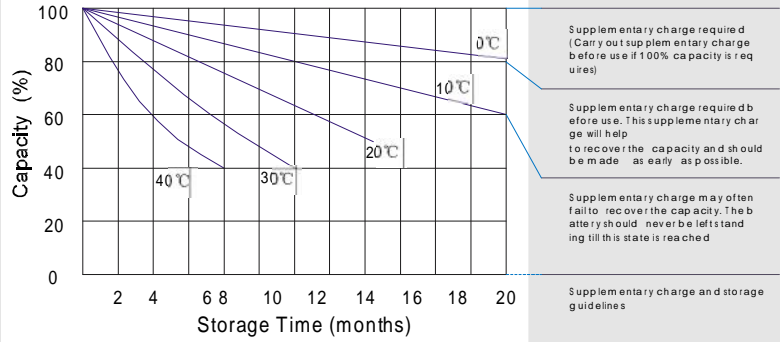

Life characteristics of cyclic use

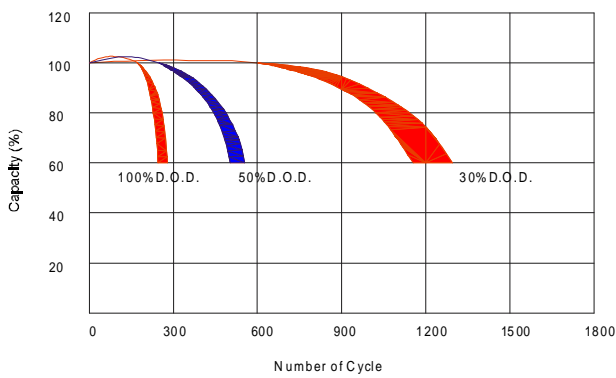

Effect of Temperature on long term float life

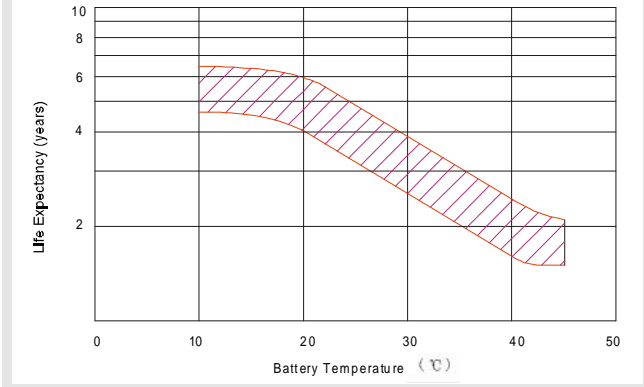

Charge characteristic curve for standby use

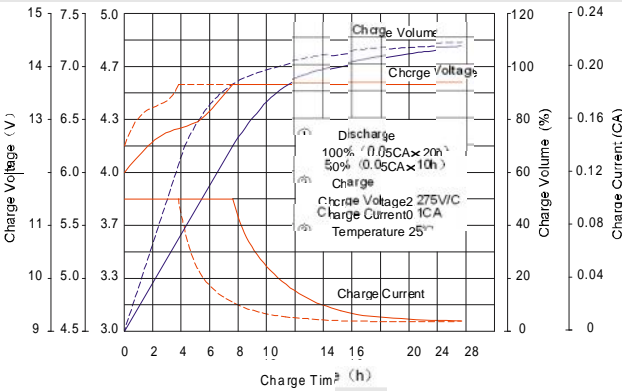

Discharge characteristic curve

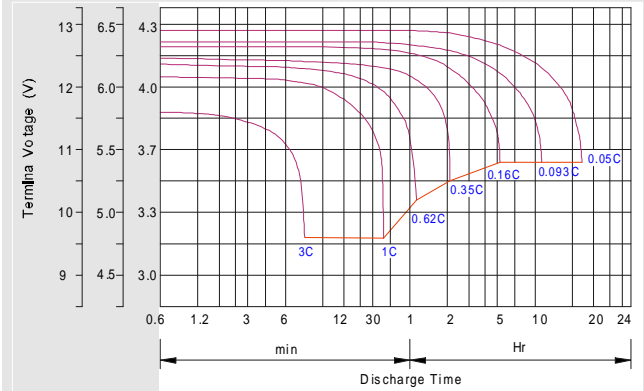

Charging Procedures

Application	Charge Voltage (V)			Max. Charge Current
	Temperature	Set point	Allowable range	
Cycle Use	25°C	14.7	14.4-15.0	0.3C
Standby	25°C	13.7	13.6-13.8	0.3C

Discharge Current VS. Discharge Voltage

Final Discharge Voltage V/cell	1.75V	1.70V	1.60V
Discharge Current (A)	A 0.2C	0.2C < (A) <	(A) ≥ 1.0C

Charge the batteries at least once every six months, if they are stored at 25°C.

Charging Method:

Constant Voltage	7.25~7.45V, 5~11h, Max. Current 0.1CA
Constant Current	0.1CA x 5h
Fast	0.3CA x 1.7h

Charging Procedures (6V series)

Application	Charge Voltage (V)			Max. Charge Current
	Temperature	Set point	Allowable range	
Cycle Use	25°C	7.35	7.25-7.45	0.3C
Standby	25°C	6.85	6.8-6.9	0.3C

QIANGJUN BATTERY CO., LTD
 Mudan Road Xiacheng Town,
 Yuetang District,
 Xiangtan City, Hunan P.R.China